

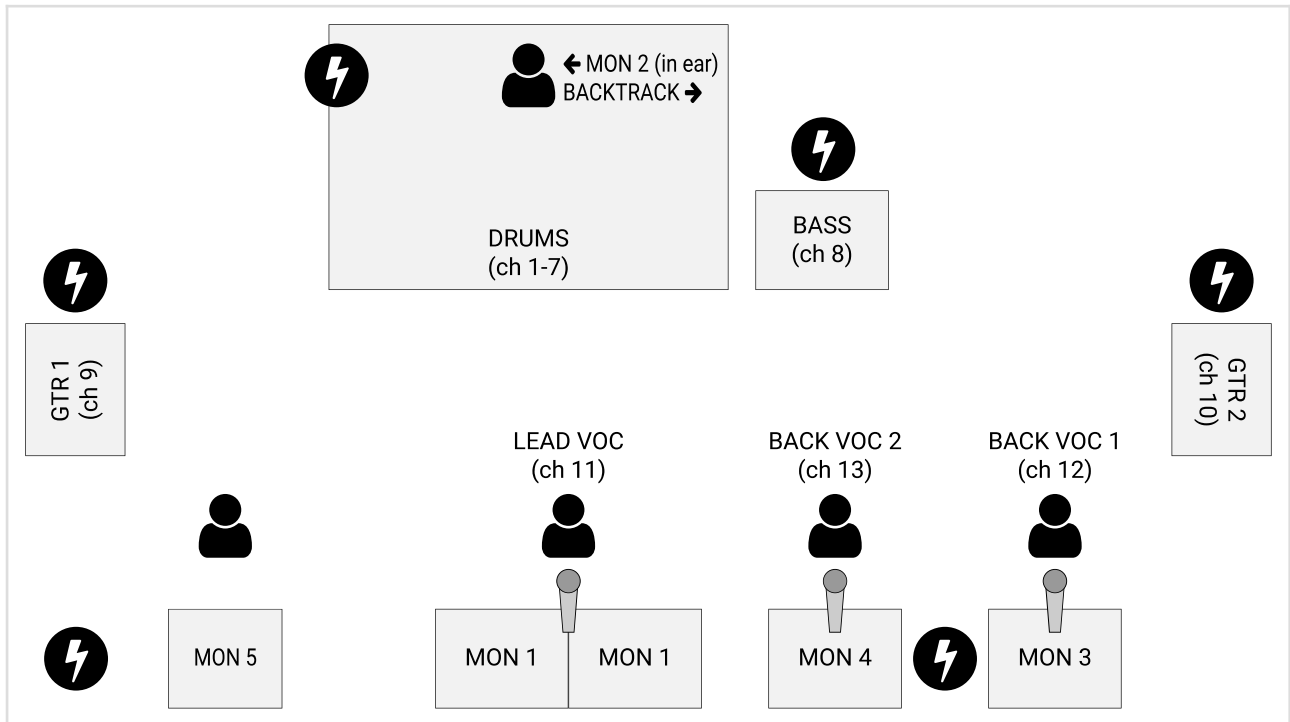

Brooke Logans technical rider

26.03.2025

Stage plan



Channel list

Channel	Source	Mic/Line	Stand	Insert
1	Kick drum	Beta 52/e602/D112	Short boom	Comp + gate
2	Snare drum	SM57/Beta 57/e904/e604	Short boom	Comp
3	Rack tom 1	e604/e904/Opus 87/SM57	Clip preferred	Gate
4	Rack tom 2	e604/e904/Opus 87/SM57	Clip preferred	Gate
5	Floor tom	e604/e904/Opus 87/SM57	Clip preferred	Gate
6	Overhead 1	Condenser	Long boom	
7	Overhead 2	Condenser	Long boom	
8	Bass DI	Active DI		
9	Guitar 1	e960/SM57	Short boom	
10	Guitar 2	e960/SM57	Short boom	
11	Lead voc	e935/Beta58/SM58	Long straight	Comp
12	Back voc 1	SM58/Beta58	Long boom	Comp
13	Back voc 2	SM58/Beta58	Long boom	Comp
14	Backtrack	Mono line		

Monitor 1 is usually replaced with in ear monitoring for the lead singer so actual stage monitors may not be needed. If using e906 for guitars they can be hung from the microphone cable and taped to the cabinet, this way no need for stands for guitar mics.

PA

The PA-system must be modern, high-quality and factory made with the capability to produce enough sound pressure to cover the whole venue. This includes also the bottom of the audio spectrum, so some kind of subwoofer is required.

FOH

High quality mixing desk with enough channels (minimum 16) and auxs (minimum 3 of which 2 pre fader and 1 post fader).

Preferred desks: Yamaha LS9/DM1000/01V96 (not the old 01V), Midas, Soundcraft GBseries/MH-series/Vi&Si-series, Allen&Heath GL-series/MixWizards etc.

We usually bring a small set of compressors and reverbs but having some more gear at the site never hurts. Preferred brands: dbx, bss, Klark, Lexicon, TC-electronics.

Monitors

Minimum 2 monitor groups and 4 monitor cabinets required. The monitor cabinets must be modern, high-quality and factory made with the capability to produce enough sound pressure to the venue's stage.

Backline

Usually we travel with our own backline but in special cases, like when flying overseas, backline is needed.

Drums

Basically any high quality brand will do. Millenium is not a high quality brand!

Absolute minimum requirements (no show without these):

- 1 bass drum (20" – 24")
- 1 rack tom (10" – 14")
- 1 floor tom (14" – 18")
- 1 hihat stand
- 3 cymbal stands
- 1 snare stand
- 1 adjustable drum stool

Preferred minimum requirements:

- 1 bass drum (20" – 24")
- 2 rack toms (10" - 12" + 12" – 14")
- 1 floor tom (14" – 18")

- 1 hihat stand
- 4 cymbal stands, 2 of these with boom
- 1 snare stand
- 1 adjustable drum stool

2 x guitar amps (combos or heads + cabinets)

- Preferrably 15-30 watt
- Guitar amp 1 preferred brands/models: Marshall 1974 or 1974X, Vox AC15/AC30, Fender all tube amps. This amp needs a clean channel only.
- Guitar amp 2 preferred brands/models: Vox AC15/AC30, Orange Rocker 30, Fender all tube amps. This amp needs a clean channel only.
- Basically any high quality all tube amps will do.
- Cabinets preferrably 1x12" or 2x12" but 4x12" will do also. Preferred speakers: Celestion Vintage 30/G12H/Greenback, Eminence.
- Preferrably only all tube amps, we will not play with some crappy solid state practice amps!

Bass amp (combo or head + cabinet)

- Preferrably 100-300 watt all tube
- Preferred brands and models: Ampeg SVT Classic, Orange AD-200B/OBC410
- Basically any high quality bass amp will do
- Show can be played without a bass amp with the bass going only DI to PA but using an amp on stage is preferred.

General

Brands such as Behringer, T-amp/box, Alto, Phonic, Samson etc. do not qualify as "high quality".

We understand that not every venue can meet our specifications so everything is negotiable!

Contact

If you have any questions, don't hesitate to contact us.

Sound technician

Ossi Miikkulainen / +358 50 3740068 / ossi.miikkulainen@gmail.com

Brooke Logans

Hape Haavikko / +358 50 5878016 / hape.haavikko@fakiirimedia.com